

RELAYS (NONWIRE SPRING-TYPE), 197-TYPE SWITCHES, AND KS-13835 (AMA) READER—HAVING UNUSUAL CONTACT CONDITIONS REPLACEMENT CONTACTS

1. GENERAL

.01 This section covers the cases where silver replacement contacts are recommended for use on certain apparatus in circuits where heavy contact erosion occurs. It also covers those cases where No. 1 metal replacement contacts are recommended where frequent contact opens occur.

1.02 This section is reissued to revise 1.04 and to add new Fig. 1.

1.03 In some cases, mating palladium contacts having contact protection show heavy erosion on the negatively poled contact with little erosion or buildup on the positively poled contact. Except as stated below, the P-16A222 silver contact is recommended for the negative contact with a mating palladium contact in these cases. This combination of contacts, referred to as silver negative (AG—) and palladium positive (Pd+), should not be used for contacts controlling the 46-ohm stepping magnets on switches in step-by-step offices. Mating palladium contacts should be used in this case. If arcing occurs with the silver negative and palladium positive combination and the arcing cannot be eliminated by vigorous burnishing of the contacts, the silver contact should be replaced with a palladium contact. Typical examples for the substitution of the silver for the palladium contact are covered in Part 2 of this section.

Note: Replace only the worn contact of a contact pair.

1.04 On step-by-step relays and 197-type switch vertical-off-normal (VON) springs with dome-shaped contacts, it will be satisfactory to replace only one contact of a pair leaving a dome contact mating with a bar contact providing satisfactory alignment is obtained. In this case, the dome must lie wholly within the length of the

bar and the center line of the dome must be within 0.010 inch of the center line through the width of the bar as gauged by eye. (See Fig. 1.)

1.05 In some cases, mating palladium contacts which do not make or break current show frequent contact opens. In these cases, No. 1 metal (P-15A847) contacts are recommended as replacements for both palladium contacts to give increased contact reliability. Substitution of No. 1 metal contacts for palladium contacts is restricted to the applications covered in Part 3 of this section.

1.06 Section 069-310-802 covers the procedures for replacing the contacts on the apparatus referred to herein.

2. P-16A222 (SILVER) CONTACT

2.01 Tables A through D cover typical examples where the silver (P-16A222) contact is recommended for use as the negatively poled contact with a mating palladium (positive) contact. These examples are given with reference to the switching systems in which they occur and are subject to the limitations covered in 1.03.

Caution: Before making the contact replacement, check for the negative (battery) side of the contact pair in order to insure applying the silver contact to this side. In some cases, the poling of the contacts may differ from that indicated on the circuit drawing because of local wiring deviations.

3. P-15A847 (NO. 1 METAL) CONTACT

3.01 Tables E, F, and G cover all cases where the No. 1 metal (P-15A847) contact is recommended for use where frequent open contact troubles occur. Replace both mating contacts.

NOTICE

Not for use or disclosure outside the
Bell System except under written agreement

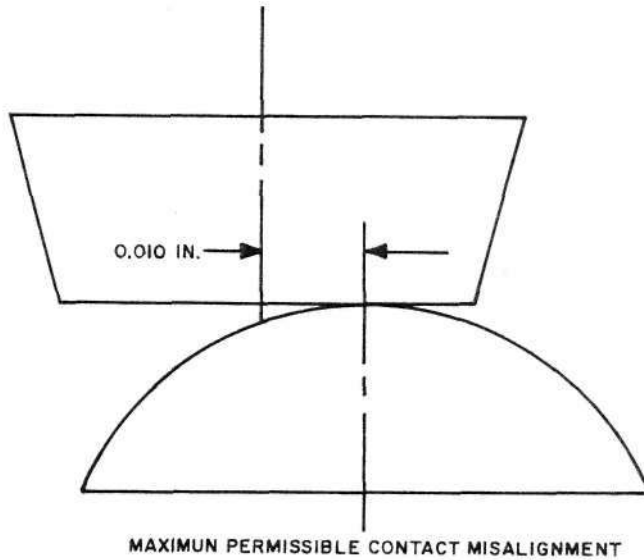
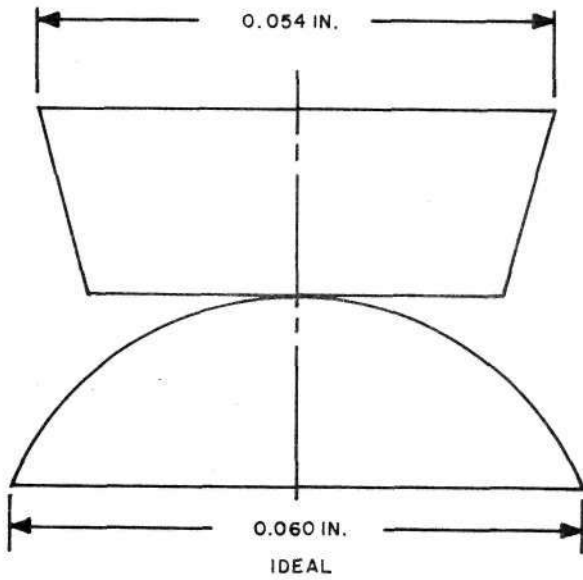

Fig. 1—Dome-Shaped Contact Mating With a Bar Contact

TABLE A

STEP-BY-STEP SYSTEM (CO, PBX, CDO)

1. Contacts that control a switch vertical or rotary stepping magnet except magnets with 46-ohm winding	
RELAY DESIGNATION	CONTACT POSITIONS (See Note)
C (Line Finder)	1-2
A (Selector)	1-2
A (Connector)	1-2
E (Selector)	1-2 or 3-4
SP (Line Finder — SD-31731-01)	1-2T
2. 197-type switch VON contacts 1-2, 3-4, or 5-6 depending on which contacts break the circuit to the release magnet	

Note: In a few cases, the vertical or rotary stepping magnet is controlled from a different contact position. In such cases, it is permissible to apply the silver contact on the negative contact of this position. If dome contacts are provided and the positive dome contact is not excessively worn, replace only the negative contact. Refer to 1.04 for the required alignment of the bar and dome contacts.

TABLE B

NO. 4A TOLL SWITCHING SYSTEM

SD-68340-01 Decoder Circuit (U-Type Relays)		
RELAY DESIGNATION	CONTACT POSITIONS	
	TOP	BOTTOM
HTR	4-5	5-6
	6-7	7-8
	8-9	9-10
	10-11	
OC	3-4	1-2
	5-6	3-4

TABLE C
NO. 5 CROSSBAR SYSTEM

SD-25550-01 Marker (U-Type Relays)		
RELAY DESIGNATION	CONTACT POSITION	
	TOP	BOTTOM
FR	1-2	3-4
FTK1		1-2
HTK1	1-2	
GK	1-2	1-2
VGR		3-4
HGT0-9	5-6	
VGT0-6	7-8	
VFTQ-4	5-6	
TLC2	1-2	
D1S1		3-4
LLC1	9-10	
D	1-2	7-8
	7-8	9-10
	9-10	
CKG1	5-6	
LK1		9-10
CON1		6-7
CKG3	1-2	3-4
CB		1-2
STF		2-3
CBF		1-2
VFL1		1-2
TBK	3-4	
MAK1	3-4	
NSO		1-2
GTL		5-6
FBK	1-2	
GLH		7-8
		9-10
FCK	4-5	1-2
		4-5
RYT	1-2	
CKG5	11-12	

TABLE D

AMA CENTER

1. SD-40002-01 Computer Circuit (UB-Type Relays)			2. SD-40019-01 Assembler Circuit (UB-Type Relays)		
RELAY DESIGNATION	CONTACT POSITIONS		RELAY DESIGNATION	CONTACT POSITIONS	
	TOP	BOTTOM		TOP	BOTTOM
A. Reading Relays			A. Reading Relays		
AO	1-2 5-6	1-2 5-6	A0	7-8	
A1	3-4 5-6	1-2 3-4	A1		5-6 7-8
A2	1-2 3-4	5-6	A2	5-6	
BO to FO	1-2 5-6 9-10	7-8 9-10	B0 to F0	5-6	
B1 to F1	1-2 3-4 5-6 7-8 9-10	5-6 9-10	B1 to F1	5-6 7-8	
B2 to F2	1-2 3-4 5-6 7-8 9-10	1-2 9-10	B2 to F2	5-6 7-8	
B4 to F4	1-2 3-4 5-6 7-8 9-10	3-4 9-10	B4 to F4	5-6 7-8	
B7 to F7	1-2 5-6 9-10	3-4 9-10	B7 to F7	5-6	3-4 7-8
B. Other Relays			B. Other Relays		
RSI	11-12		PA0 to PA9	All	All
RS2	11-12	3-4 7-8	PB0 to PB9	All	All
			PC0 to PC9	All	All
			KA0 to KF7	5-6	
			RS3	5-6	
			RS4	5-6	
				-	5-6 7-8 3-4 5-6 7-8

TABLE D (Cont)

AMA CENTER

3. SD-40003-01 Sorter Circuit (UB-Type Relays)		
RELAY DESIGNATION	CONTACT POSITIONS	
	TOP	BOTTOM
A. Reading Relays		
A0	1-2 3-4 5-6	
A1	1-2 3-4 5-6	
A2	1-2 3-4 7-8	
BO to F7	1-2 3-4 5-6 7-8	3-4 5-6 7-8
B. Other Relays		
PAO to PA9	7-8 9-10	1-2 3-4 5-6 7-8 9-10
PBO to PB9 and PCO to PC9	1-2 3-4 5-6 7-8 9-10	1-2 3-4 5-6 7-8 9-10
KA0 KA1 KA2	5-6	3-4 3-4
KBO to KF7	1-2 3-4 5-6	1-2 3-4
RS1 RS2		9-10 9-10
4. KS-13835 Reader		
A. All reading and control cont acts.		

TABLE E

STEP-BY-STEP SYSTEM

1. SD-32183-01 Digit-Absorbing Selector (See Note)	
APPARATUS DESIGNATION	CONTACT POSITIONS
VON Springs F Relay Z Relay	3-4 7-8 T and B 7-8
2. SD-30976-01 Digit-Absorbing Selector	
APPARATUS DESIGNATION	CONTACTS
B Relay VON Springs	1-2 6-7

Note: All SD-32183-01 digit-absorbing selectors bearing manufacture dates September 1956 and later have No. 1 metal contacts in the contact positions listed. During the period of introducing these contacts, some selectors manufactured prior to September 1956 were equipped with No. 1 metal contacts in these positions. These selectors may be identified by the 1/8-inch diameter green dot stamped on the pole pieces of F and Z relays and the bracket of the VON spring assembly.

TABLE F

PANEL SYSTEM

1. SD-21193-01 Subscriber Sender Circuit			
RELAY DESIGNATION	CONTACT POSITIONS (See Note)		
	TOP		BOTTOM
P1 ¹	2-3 or 4-5		
P2 ¹	3-4	and	2-3 or 1-2 4-5
P3 ¹	2-3		
P4 ¹	3-4	and	2-3
P5 ¹	4-5	and	1-2

2. SD-21193-02 Subscriber Sender Circuit			
RELAY DESIGNATION	CONTACT POSITIONS (See Note)		
	TOP		BOTTOM
P1 ¹	2-3 or 4-5		
P2 ¹	3-5	and	2-3 or 1-2 4-5
P3 ¹	2-3		
p4 ¹	3-4	and	2-3
P5 ¹	2-3 or 4-5 or 4-5		
		and	1-2

Note: Break contact that controls operating path of CK relay.

TABLE G

NO. 4A TOLL SWITCHING SYSTEM

SD-68221-01 DP and SD-68222-01 MF Sender Circuit		
RELAY DESIGNATION	TOP	BOTTOM
MF	5	5
MF2	1 3 5 7	1 3 5
MF3	1 3 5 7 9	3 5 7 9 11